

# Fluorescence-based Lab-on-Chip Spot Design for Improved Signal Detection

Thiago Bassani (*EMBS Graduate Student*), *Philippe Dias, Gilberto Branco, Wilson J. da Silva, Hugo Vieira Neto and Fábio K. Schneider (Member IEEE)*

**Abstract**—This work presents a new perspective for fluorescence signal detection using specific optics on Lab-on-Chip devices. An apparatus was designed and implemented in order to assess the performance of a fluorescence technique using different detection spot configurations, using the chip itself as a waveguide for illumination. The experiments conducted investigate the influence of the dimensions – diameter and height – of the spot on the amplitude of the detection output signal. Results show that the configuration of optical interfaces must be considered in order to improve detection output, or to be able to detect less fluorophore molecules in the spot.

## I. INTRODUCTION

Despite technological advances in public health, a pandemic with devastating proportions as the Spanish Influenza may recur, according to a consensus in the United Nations (UN) [1]. Hence, the World Health Organization (WHO) has among its main roles the objective of stimulating actions and work to avoid epidemic and endemic diseases, minimizing further calamities [2]. Endemic infectious diseases are a major health problem among developing countries, causing millions of deaths each year at increasing rates [3]. These diseases have high incidence among children and young people, causing significant losses to the productive and economic potential of these countries. The majority of those diseases, such as Chagas, syphilis, HTLV1, HTLV2, HIV1, HIV2, hepatitis B and hepatitis C, can be diagnosed by immunoassay techniques. The diagnostic of such diseases has crucial importance for the implementation of policies for endemic control [4].

A specific example of an immunoassay technique is the indirect immunofluorescence assay (IFA), a recommended technique due to the high sensitivity achieved. IFA could be essential for the correct therapeutic treatment for serological tests, such as the ones used to detect the Chagas disease [5]. Immunofluorescence is based on the fluorescence technique, a short-lived emission from the singlet to ground state with spin paired electrons, with decay time about  $10^{-9}$  and  $10^{-6}$ s. The diagnostic process using such technique can use the detection signal amplitude, but its fast decay time needs devices with high frequency response [6]. In this work we use the signal amplitude in order to assess the ability to detect different concentration of fluorophore molecules [7], [8].

Lab-on-chip (LOC) technology aims at the development of methods that miniaturize the chemical process, integrating sample treatment, mixing and detection on the same device,

called chip [9]. Miniaturization allows a significant reduction in the use of chemical reagents and sample consumption, which makes these devices suitable for use in the field and feasible for demographic endemic control. Therefore, there is a strong demand for lightweight, reliable, and robust LOC devices, which should also be of low-cost and simple to operate.

In several LOC devices, the optical system is built integrated to the chip, specially when Polymethyl Methacrylate (PMMA) is used as substrate [10], [11], [12]. These devices benefit from the use of low-cost raw material, and the feasibility of using mass production technologies to fabricate them [13]. The PMMA can be structured by hot embossing and is transparent for visible light, and therefore is well suited to be used as substrate for LOC devices. However, although previous works successfully demonstrated the feasibility of construction of small LOC systems, the optical system in the chip was not characterized. This work presents a new perspective for the optical system design of these devices, aiming at improving signal detection output.

## II. METHOD

The apparatus designed and implemented in this work, shown in figure 1, intends to perform an immunofluorescence technique [14]. This technique is used to detect the presence of a specific antibody by using its respective antigen attached to a fluorescent dye. In our experiments, the dye is placed in the detection spot located at the plate of the apparatus, as illustrated in figure 2. The apparatus is used to assess the differences between fluorescence measurements using different detection spot configurations, having the plate itself as waveguide for illumination of the spot.

The plate (item E) fits into its support (item D), as shown in figure 1, and is made of Polymethyl Methacrylate (PMMA), which has a refractive index of 1.49624 for the wavelength of 505nm [15], [16]. The plate is composed of three parts: waveguide, detection spot, and mechanical alignment locks. The LED present in the LED support (item C) is placed in such a way as to illuminate the end of the waveguide, as shown figure 2. The waveguide (item E.1 in figure 2) guides the LED light to the detection spot. The detection spot (item E.2 in figure 2) is a standard lab-on-chip spot with cylindrical shape, which is filled with fluorescent dye diluted in saline solution. Finally, an optical filter (item B) and the detector (item A) is placed orthogonally to the illumination waveguide, at the top of the cylindrical detection spot. Mechanical alignment locks (item E.3 in figure 2) are

\*This work was supported by the National Institute for Innovation in Diagnostics for Public Health (Brazil)

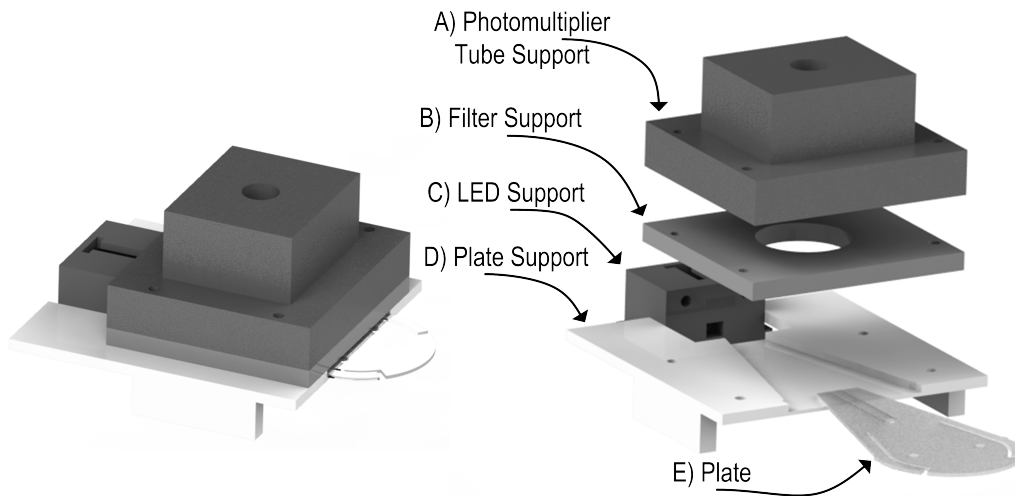

Fig. 1. The device for illumination and detection of the spot in our Lab-on-Chip design.

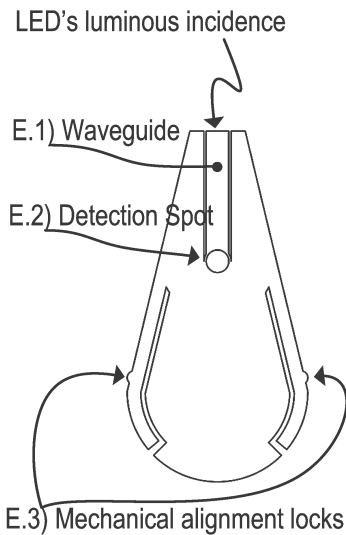

Fig. 2. Details of the plate (item E in figure 1).

responsible for keeping the plate in place once it is aligned with the detector.

Before the light excites the fluorophore in the detection spot, it passes through two optical interfaces: LED-Waveguide and Waveguide-Spot. The LED light is collimated by a lens whose focal distance is adjusted to focus the light on the end of the waveguide, as shown in figure 3. After being collimated, the light enters the waveguide via the LED-Waveguide optical interface (item E.1.1). This optical interface is located at the top of the diagram of plate shown in figure 2, where the LED light enters the plate. The Waveguide-Spot is the next optical interface (item E.1.2) and has major importance in this study, because increases in the diameter of the spot modify the resulting optical system.

The LED emission wavelength is centered at 505nm (cyan light) and was driven by a pulse-width modulated (PWM) signal with duty cycle of 31%, frequency of 1kHz,

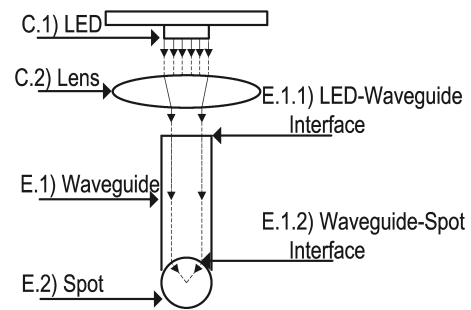

Fig. 3. Details of the optical system illustrating the light path.

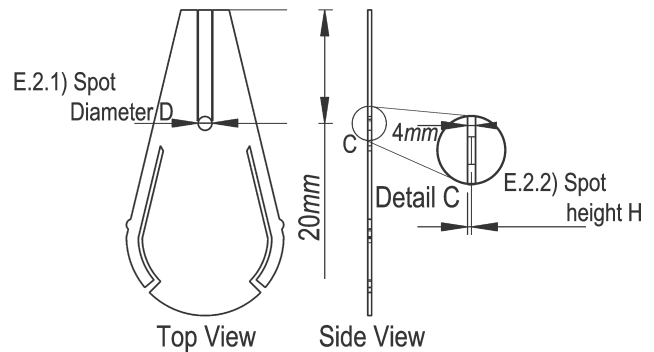

Fig. 4. Plate design showing details of spot diameter and height.

and amplitude of 2.2V, resulting in a radiometric power of 10mW. The detection sensor used was a Hamamatsu R5600 series Photomultiplier Tube (PMT) with a cathode radiant sensitivity of 15mA/W (at the dye emission band). However, the PMT also senses a background noise signal due to the LED illumination. In order to reduce illumination noise, a bandpass filter centered at 580nm with full width at half maximum (FWHM) of 10nm was used. After the bandpass filter, the detected signal from the dye by the PMT has a square waveform. The plateau of this square

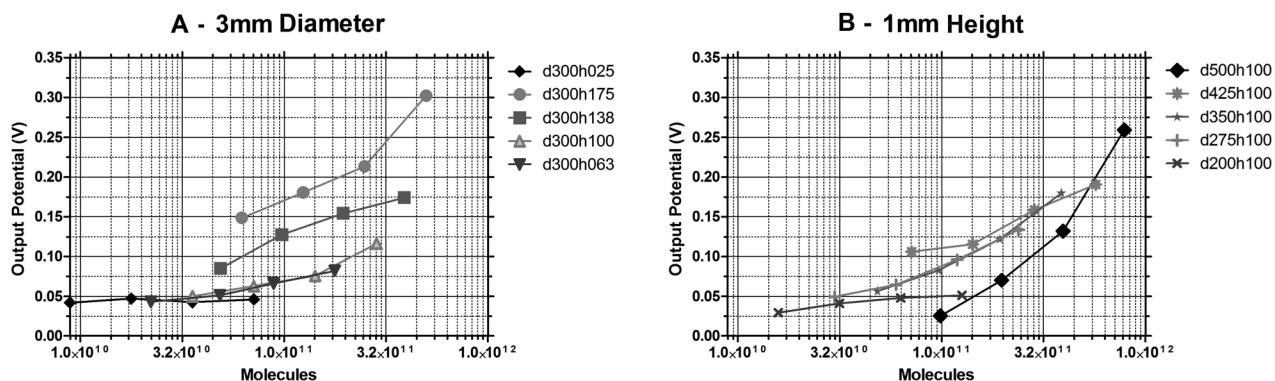

Fig. 5. Experimental results obtained for spot configuration design sets A and B. Design set A has fixed spot diameter (3mm) and varied heights, while design set B has fixed spot height (1mm) and varied diameters.

wave is proportional to the amount of photons received from the dye by the PMT, which can be compared to the noise signal detected from the spot when there is no fluorophore (baseline). The plateau amplitude also suffers from high frequency noise due to stochastic processes in the charge multiplication of the PMT [17]. As the acquired data can be smoothed off line in order to improve the signal-to-noise ratio, we averaged the data using the geometric mean with a confidence interval of 95%.

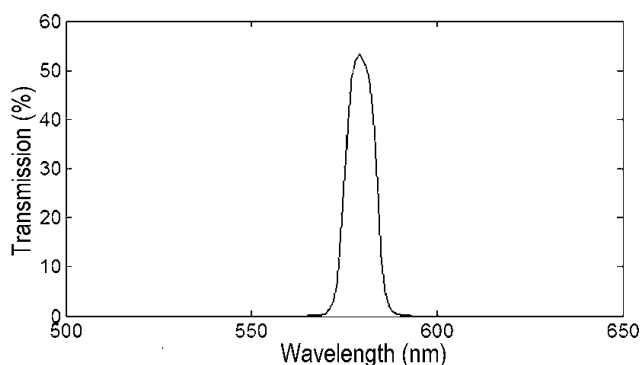

Fig. 6. The filter transmission graph, centered in 580 nm, that was applied to the block the cyan LED excitation wavelength, centered in 505nm.

The fluorophore used in our experiments is the R-Phycoerythrin (RPE), which is used as fluorescence-based indicator in indirect immunofluorescence assays. The RPE is a red protein from the light-harvesting phycobiliprotein family, whose absorption peak is located at 565nm and whose emission peak is located at 578nm. In order to achieve a detection sensitivity over the RPE fluorophore molecule amount, the experiments were conducted with four fluorophore dilutions in saline solution: 1:250; 1:500, 1:1,000 and 1:2,000. Although the standard notation is to relate detection signal to dilution, this notation is difficult to be used for different spot volumes and different dilutions. Therefore, we chose to use the number of molecules as standard unit in our experiments.

### III. RESULTS

The apparatus aims at assessing how different detection spot configurations influence differences in fluorescence measurements. The cylindrical spot configuration is analyzed using different diameters and heights. The following notation is used in this work: a specific nomenclature is used to distinguish different spot configuration samples, in which the letter  $d$  is followed by the diameter in tens of  $\mu\text{m}$  and the letter  $h$  is followed by height of the spot in tens of  $\mu\text{m}$  – e.g.  $d300h100$  stands for 3mm diameter and 1mm height. Changes in these dimensions are then used to assess the resulting effects in fluorescence measurements.

The data are composed by ten different detection spot configurations, divided in two design sets: A) fixed diameter and B) fixed height. Each design set intends to assess the influence of variations in one of the two cylindrical spot parameters when the other is fixed – 3mm diameter and 1mm height, respectively. All experiments were conducted using the dilutions of: 1:250; 1:500, 1:1,000 and 1:2,000. Therefore, a single detection spot configuration has four samples representing the signal detection results for each of the four dilutions, as shown in figure 5. Each sample in the graphs is the result of the geometric mean of 2,000 samples from the output plateau of the output signal of the PMT, adding up to 80,000 data samples.

The smallest dilution (1:250) produces the highest output signal and increasing dilutions result in output signal decrease following an exponential pattern. The increase in height causes an increase in the output signal, as shown by graph A in figure 5. The  $d300h175$ ,  $d300h138$  and  $d300h100$  configurations have curves with similar trends but different offsets, with the highest height corresponding the highest output signal. The  $d300h063$  configuration represents the lower boundary – it has the lowest output signal above the confidence level in this design set. The  $d300h025$  configuration did not present output signals above the confidence level.

The results of the configurations presented in graph B in figure 5 indicate a different behavior when compared to graph A. The  $d275h100$ ,  $d350h100$  and  $d450h100$  configu-

rations approximately follow exponential patterns. However, the  $d500h100$  configuration shows a distinguished exponential pattern, with a higher derivative.

#### IV. CONCLUSIONS

The results of our experiments show that an increase in detection spot volume, filled with fluorescence dye, does not necessarily imply in an increase of the output signal, as shown in figure 5, graph B. This suggests that using this setup, the most adequate detection spot design configurations for few molecules are  $d200h100$  and  $d300h175$  for high output signals. However, it is crucial to know the effect of the detection spot design in the optical measurements.

One could assume that increasing the detection spot volume, i.e. increasing the amount of fluorophore, would imply in increasing the output detection signal. However, the present paper shows that increasing the diameter or the height of the detection spot causes different output patterns than this naive assumption. The output pattern when the diameter is increased leads to lower output detection signals. This fact occurs due to geometric variations in the Waveguide-Spot optical interface.

The  $d500h100$  configuration has the highest volume ( $19\mu\text{l}$ ) and amount of fluorescence molecules. Nevertheless, the  $d300h175$  configuration, which has less volume ( $12.37\mu\text{l}$ ) presented higher output signals. The same pattern is observed between configurations  $d350h100$  and  $d300h138$ , with the respective volumes of  $9.62\mu\text{l}$  and  $9.72\mu\text{l}$ , in which the latter presents a higher output signal.

Therefore, the configuration of optical interfaces influences the amplitude of the detection output signal and plays an important role when one desires to detect fewer fluorophore molecules. Assessing different detection spot configurations will eventually lead to improvements in the Lab-on-Chip detection signal amplitude.

In conclusion, this paper presented how the diameter and the height of the detection spot in a Lab-on-Chip device influence the detection output signal. The fabrication techniques and device measurements used in the design used in the experiments are suitable for industrial production. Consequently, the reader can apply this practical knowledge directly to Lab-on-Chip devices.

#### REFERENCES

- [1] J. K. Taubenberger and D. M. Morens, "1918 Influenza: the mother of all pandemics." *Emerging infectious diseases*, vol. 12, no. 1, pp. 15–22, Jan. 2006. [Online]. Available: <http://www.ncbi.nlm.nih.gov/pubmed/16494711>
- [2] World Health Organization, "Constitution," pp. 1–18, 2006.
- [3] D. Mabey, R. W. Peeling, A. Ustianowski, and M. D. Perkins, "Diagnostics for the developing world." *Nature*, vol. 2, no. 3, pp. 231–40, 2004. [Online]. Available: <http://www.ncbi.nlm.nih.gov/pubmed/15083158>
- [4] J. C. P. Dias, a. C. Silveira, and C. J. Schofield, "The impact of Chagas disease control in Latin America: a review." *Memórias do Instituto Oswaldo Cruz*, vol. 97, no. 5, pp. 603–12, Jul. 2002. [Online]. Available: <http://www.ncbi.nlm.nih.gov/pubmed/12219120>

- [5] L. Foti, B. d. P. F. e. Fonseca, L. D. Nascimento, C. d. F. S. Marques, E. D. da Silva, C. A. B. Duarte, C. M. Probst, S. Goldenberg, A. G. Pinto, and M. A. Krieger, "Viability study of a multiplex diagnostic platform for Chagas disease," *Memórias do Instituto Oswaldo Cruz*, vol. 104, pp. 136–141, 2009. [Online]. Available: <http://www.scielo.br/scielo.php?pid=S0074-02762009000900019&script=sci.arttext>
- [6] P. M. Gewehr and D. T. Delpy, "Optical Oxygen Sensor Based on Phosphorescence Lifetime Quenching and Employing a Polymer Immobilized Metalloporphyrin Probe," *Theory and Instrumentation*, vol. 31, no. 1, pp. 2–10, 1993.
- [7] S. V. Overmeire and H. Ottevaere, "Miniaturized detection system for fluorescence and absorbance measurements in chromatographic applications," *IEEE Journal of Selected Topics in Quantum Electronics*, vol. 14, no. 1, pp. 140–150, 2008. [Online]. Available: [http://ieeexplore.ieee.org/xpls/abs\\_all.jsp?arnumber=4451133](http://ieeexplore.ieee.org/xpls/abs_all.jsp?arnumber=4451133)
- [8] L. Mik, J. Stepien, M. Jastrzab, W. Kucewicz, and M. Sapor, "System for Low Intensity Fluorescence Light Measurement based on Silicon Photomultiplier," in *International Conference on Signal and Electronic Systems*, 2010, pp. 383–386.
- [9] P. S. Dittrich, K. Tachikawa, and A. Manz, "Micro total analysis systems. Latest advancements and trends." *Analytical Chemistry*, vol. 78, no. 12, pp. 3887–908, 2006. [Online]. Available: <http://www.ncbi.nlm.nih.gov/pubmed/16771530>
- [10] S. Qi, X. Liu, S. Ford, J. Barrows, G. Thomas, K. Kelly, A. McCandless, K. Lian, J. Goertert, and S. a. Soper, "Microfluidic devices fabricated in poly(methyl methacrylate) using hot-embossing with integrated sampling capillary and fiber optics for fluorescence detection," *Lab on a chip*, vol. 2, no. 2, pp. 88–95, May 2002. [Online]. Available: <http://www.ncbi.nlm.nih.gov/pubmed/15100840>
- [11] M. Punke, "Organic semiconductor devices for micro-optical applications," *Proceedings of Society of Photographic Instrumentation Engineers*, vol. 6185, no. 2006, pp. 618505–618505–13, 2006. [Online]. Available: <http://link.aip.org/link/PSISDG/v6185/i1/p618505/s1&Agg=doi>
- [12] C. Vannahme, S. Klinkhammer, U. Lemmer, and T. Mappes, "Integration of Organic Semiconductor Lasers and Waveguides into PMMA based Microfluidic Lab-on-a-Chip Systems," *Nature*, vol. 380, no. 2006, p. 76128, 2010.
- [13] X. Shan, Y. C. Soh, L. Jin, and C. W. Lu, "Large Area Micro Roller Embossing Using Low Cost Flexible Mould Fabricated from Polymer-Metal Film," in *Symposium on Design Test Integration and Packaging of MEMS/MOEMS (DTIP)*, no. May, 2010, pp. 9–12.
- [14] C. R. Madeley and J. S. M. Peiris, "Methods in virus diagnosis: immunofluorescence revisited." *Journal of clinical virology*, vol. 25, no. 2, pp. 121–34, Aug. 2002. [Online]. Available: <http://www.ncbi.nlm.nih.gov/pubmed/12367646>
- [15] J. M. Cariou, J. Dugas, L. Martin, and P. Michel, "Refractive-index variations with temperature of PMMA and polycarbonate." *Applied optics*, vol. 25, no. 3, pp. 334–6, Feb. 1986. [Online]. Available: <http://www.ncbi.nlm.nih.gov/pubmed/20445691>
- [16] W. J. da Silva, I. a. Hummelgen, R. M. Q. Mello, and D. Ma, "Hybrid metal-base transistor with base of sulfonated polyaniline and fullerene emitter," *Applied Physics Letters*, vol. 93, no. 5, p. 053301, 2008. [Online]. Available: <http://link.aip.org/link/APPLAB/v93/i5/p053301/s1&Agg=doi>
- [17] S. S. Raouf, A. R. Sadik, N. K. Wafi, and K. M. Aboud, "Measurement of noise power spectrum in photon counting PMT's and The effect of the observer (1/f) noise on astronomical photometry," *Astrophysics and Space Science*, vol. 127, pp. 207–218, 1986.